

# UNIVIA<sup>®</sup> Seating & Planters.



**furnitubes**  
shaping outdoor spaces





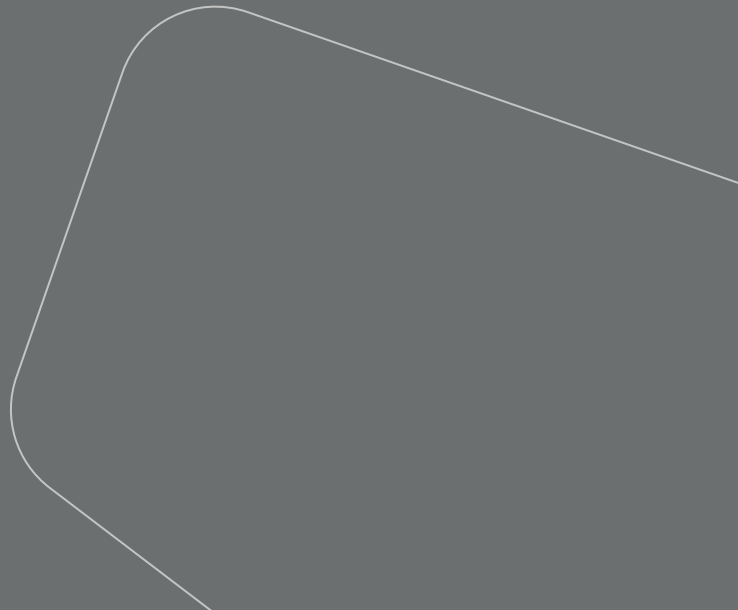
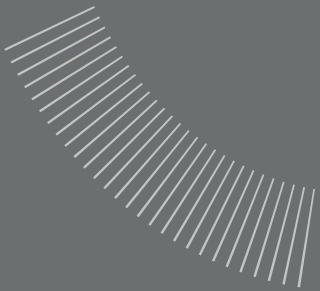
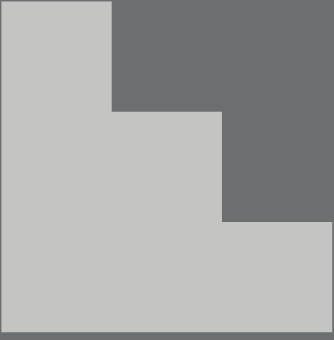

# Uniun.



**The Uniun range is built on the idea that informal seating and planter 'islands' encourage more social use of spaces than conventional linear forms.**

Unique and versatile, the range can be used as seating and planters or subdivided to provide both with one module. With its clever trapezoid geometry, Uniun modules can be arranged in unusual or abstract ways allowing people to face in different directions, or face each other.

You can combine planter and seating modules to create green buffers and backdrops between and around seating provision.

## Why use Uniun?

- Create bold seating and planter configurations
- Lightweight but tough polyethylene base
- Freestanding or bolt-down modules
- Very little maintenance required
- Ideal for roof terraces, public spaces, and schools



# How does it work?

## As a seat

### SEATING PLATFORM

A timber top affixed to a polyethylene base. A base plate not required

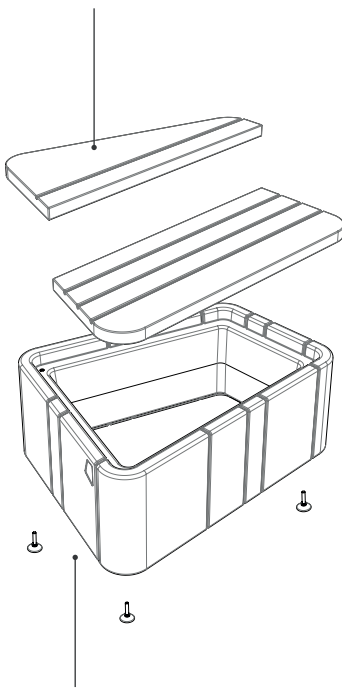

### BASE MODULING

Common to all seating & planter products. There are two orientations

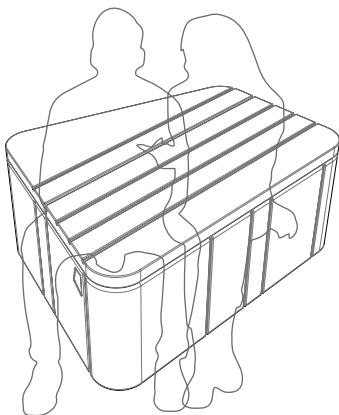

## As a planter

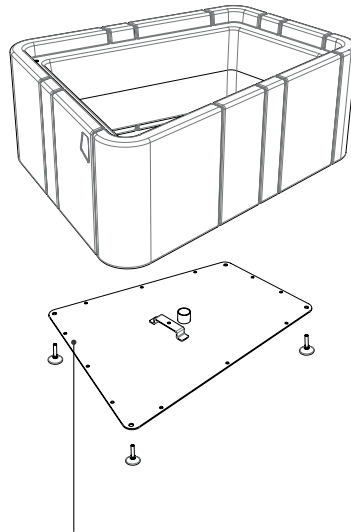

### BASE PLATE

Steel base plate fitted to underside of moulding to hold topsoil and planting

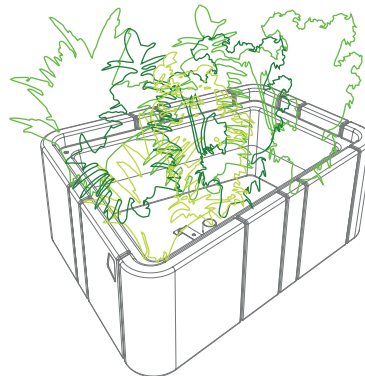

## As a hybrid

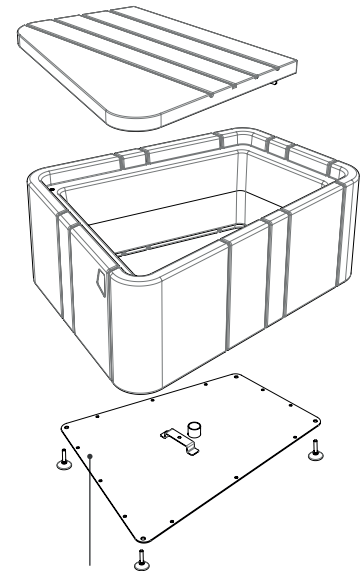

A combination of all 3 modules

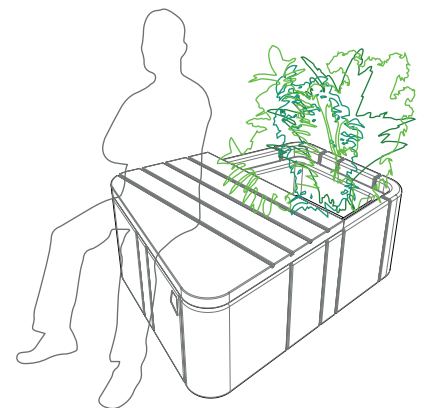

# The geometry.

The Uniun is a trapezoid, a 4-sided flat shape with straight sides and no parallel sides. We've added two opposite right-angled corners introducing further relationships between the two pairs of sides. With one adjacent pair being equal length and for the second pair, one side being twice the length of the other.

With these principles, the different sides of a module can be organised in multiple ways to create unusual but beautiful seating/planter configurations.

The base of the Uniun is common to all seating and planter modules, it can also be flipped and rotated, and used in either of its orientations. The base moulding is essentially a ring, to whichever a lid and/or a steel base plate is added. With a number of timber detailing to choose from to - Uniun presents hundreds of seating and planter possibilities.

From a single common base moulding, there are 14 different modules.

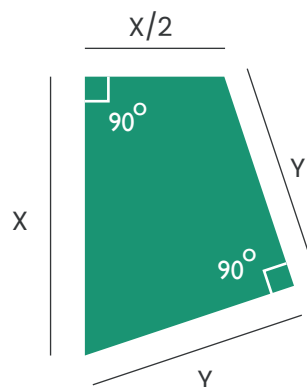

Trapezoid shape, allows alignment of different faces



# The base.

Made from rotationally moulded LLDPE (linear low-density polyethylene), the base of the Uniun is extremely durable, fully recyclable and available in a range of standard RAL colours – perfect for high-traffic public realm areas.

\*All colours are classified as all 'through-colours', scuffs will not expose any base material of a different colour.

\* For any specific colour requirements please get in touch

## Colour Options

Uniun is offered in a range of colours that help it seamlessly integrate into architectural projects while effectively concealing scuffs and marks.

The neutral Millstone grey and sleek Black, which uses recycled material to produce the base, accentuate the contrasting natural colour and texture of the timber top on benches and greenery in planter modules.

For those looking to make a bold statement, vibrant Green connects with nature while cheerful Yellow brightens up any space.

This versatile colour palette allows Uniun to complement a variety of environments, from modern urban designs to more natural settings, giving you the flexibility to choose the perfect shade for your project needs.

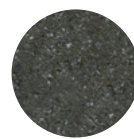

**9210**  
Millstone



**Black**

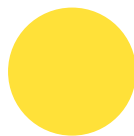

**2704**  
Yellow



**6136**  
Green





# The seating platform.

Carved from Iroko hardwood timber, these bench tops are also very durable but equally beautiful.

As standard we apply a UV protective finish in a 'teak' colour, to help retain the natural colouration of the hardwood, protecting it for a longer period. Other colours are available or if preferred, we can supply the bench tops in its natural untreated state.

**\*To maintain great long-term colouration, we recommend re-coating after 12 months.**

## Stained timber colours

As the closest colour match to natural Iroko, teak is our standard finish selected when applying UV treatment. For Uniun is possible to select Ebony UV finish which can be particularly effective when combined with a brightly coloured base. All the finishes applied allow the grain of the Iroko to clearly show through the finish coat.



**Teak**



**Ebony**





# The planter.

As a planter, the Uniun base has a built-in spout that allows 40mm of water reservoir. Once the water reaches that level it drains out through a central tube. It offers 285mm high planting space, and 50mm extra space for the addition of mulch as a top surface.

We also supply the drainage tube with a plug, in case no drainage is required.

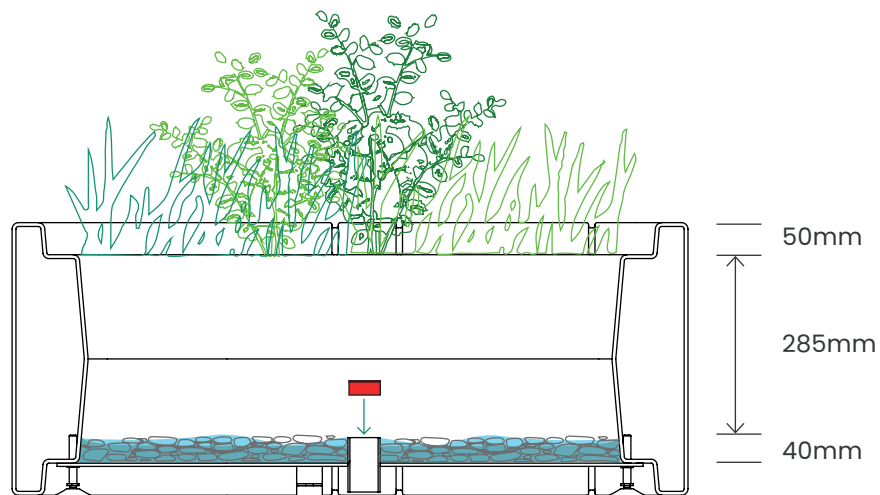



# Module options.

Please note\*\*

- Full seating platforms seat up to 4 adults
- Half platforms seat up to 2 adults
- 4 x all-seating units, each with a different platform configuration and timber detailing
- 2 x all-planter units, in the standard and reverse hand forms
- 8 x split seats/planters, each with a different half for the planting and with seating platform details to match the all-seating units

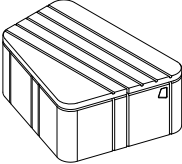
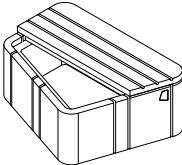
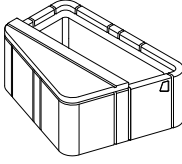
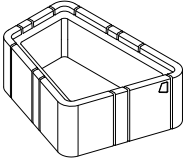
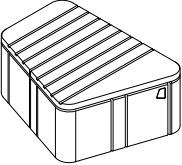
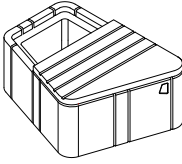
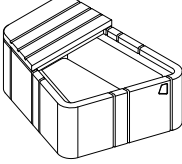
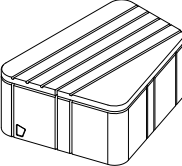
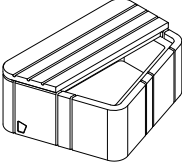
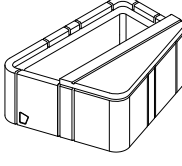
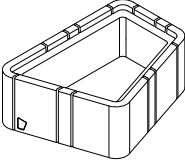
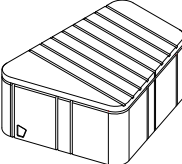
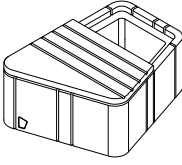
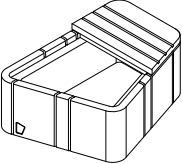
		Planter with half bench platform			
		Full Bench	(Larger Bench / Smaller Planter)	(Smaller Bench / Larger Planter)	Full Planter
Standard Module	Horizontal Timbers				
	Vertical Timbers				
Reverse Hand Module	Horizontal Timbers				
	Vertical Timbers				

# Some of the possibilities.

Uniun's unique geometry allows for unusual combinations outside of traditional seating solutions, offering different viewing perspectives and a more inclusive and social experience.

## Popular geometric configurations

The trapezoid shape of the Uniun module means they can be placed together in geometrical arrangements that are both decorative and functional at the same time. Layouts can be created using linear or island forms and by mixing seating and planter units.

Combine seating and planters to create islands, perfect for big public spaces. Or go for more linear layouts, placing straight and slightly angled modules.

The possibilities are limitless.

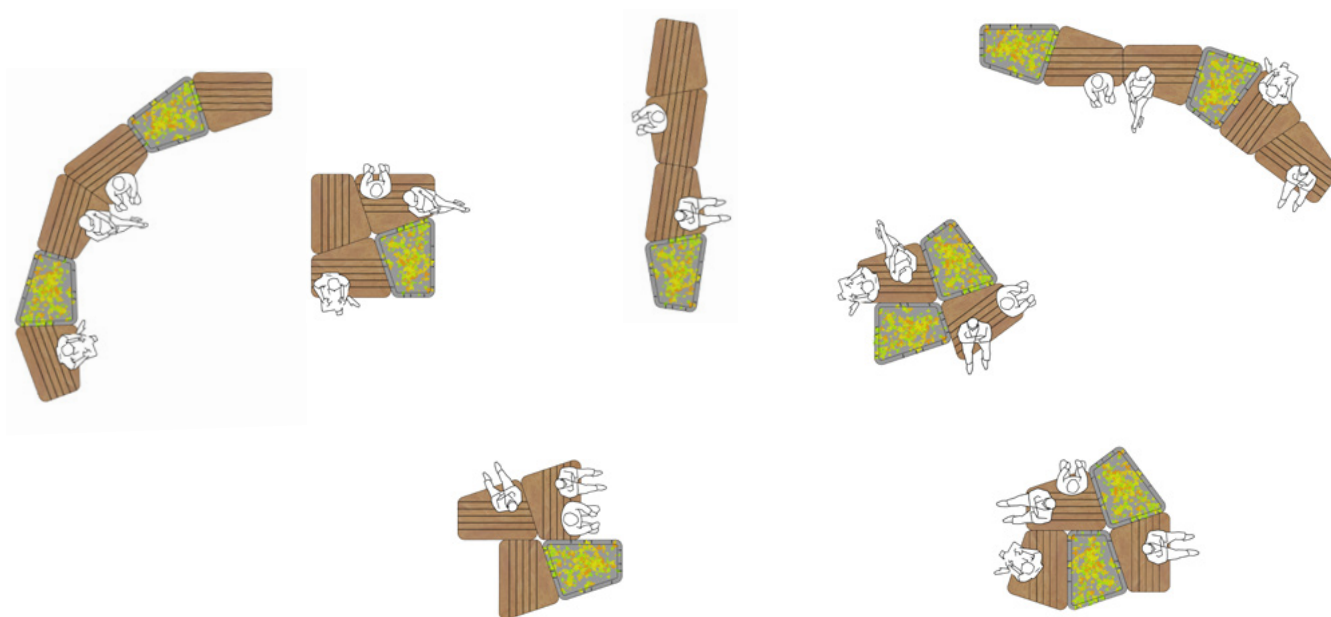



# Union all-seating modules

## General specification

- Low density polyethylene base moulding, mottled dark grey (ref. 9210), supplied c/w 2 no. ground fixing plates for bolting down
- Iroko laminated seating platform, smooth planed with UV protective finish (teak)
- 1160mm x 875mm overall plan x 480mm high

## Options (ALL MODELS)

- Base moulding in alternative colours
- Timber platform in alternative colour  
UVP treatment

Seating unit, full-size platform  
with horizontal feature lines

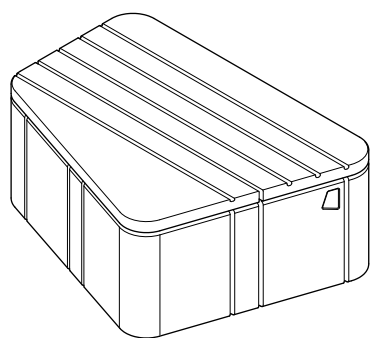
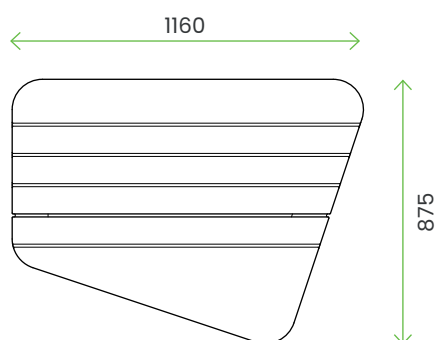

PRODUCT CODE: **UNI SBL**

Seating unit, full-size platform  
with vertical feature lines

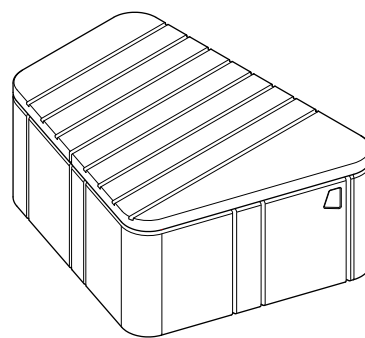
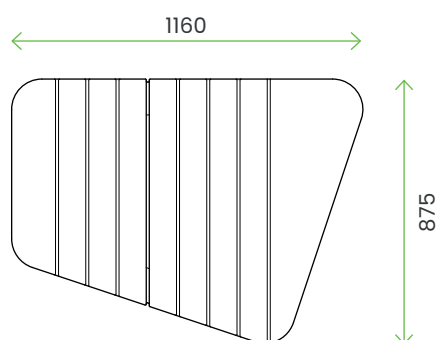

PRODUCT CODE: **UNI SBT**

# Union all-seating modules - reverse hand

## General specification

- Low density polyethylene base moulding, mottled dark grey (ref. 9210), supplied c/w 2 no. ground fixing plates for bolting down
- Iroko laminated seating platform, smooth planed with UV protective finish
- 1160mm x 875mm overall plan x 480mm high

## Options (ALL MODELS)

- Base moulding in alternative colours
- Timber platform in alternative colour UVP treatment

Seating unit, full-size platform  
with horizontal feature lines

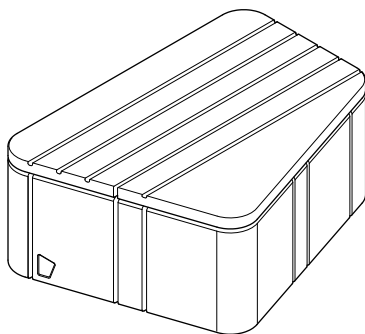
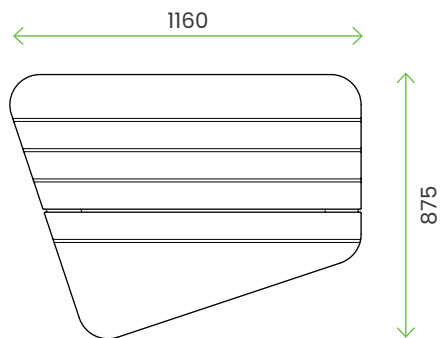

PRODUCT CODE: **UNI RBL**

Seating unit, full-size platform  
with vertical feature lines

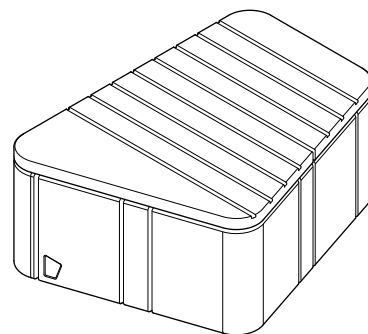
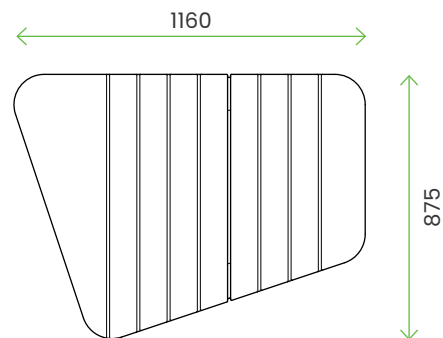

PRODUCT CODE: **UNI RBT**



# Union planter modules with half seating platform (majority seating)

## General specification

- Low density polyethylene base moulding, mottled dark grey (ref. 9210), with galvanised steel base plate
- Iroko laminated seating platform, smooth planed with UV protective finish
- 1160mm x 875mm overall plan x 480mm high
- Planter capacity 150 litres

## Options (ALL MODELS)

- Base moulding in alternative colours
- Timber platform in alternative colour UVP treatment
- Ground fixing plates (pair) for bolting down (generally not required as filled planter typically weighs 200-300kg)

Planter with horizontal half seating platform

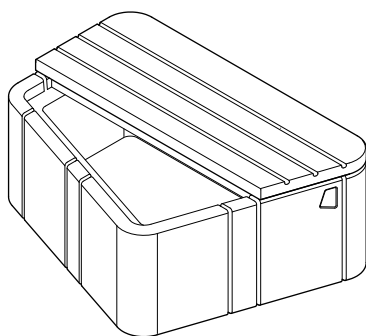
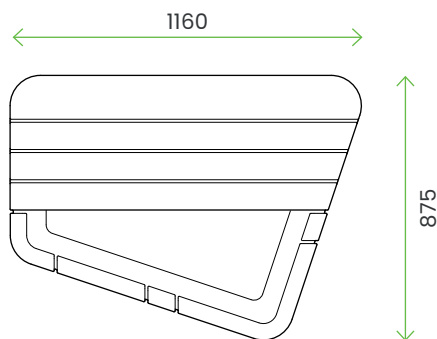

PRODUCT CODE: **UNI SLL**

Planter with vertical half seating platform

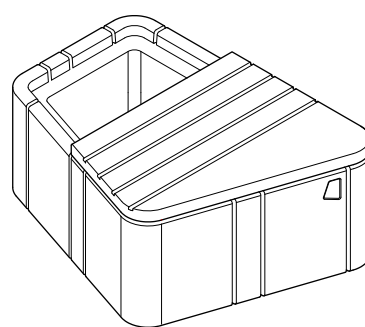
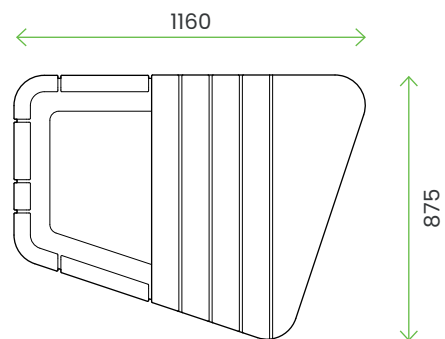

PRODUCT CODE: **UNI SLT**

# Union planter modules with half seating platform (majority seating) reverse hand modules

## General specification

- Low density polyethylene base moulding, mottled dark grey (ref. 9210), with galvanised steel base plate
- Iroko laminated seating platform, smooth planed with UV protective finish
- 1160mm x 875mm overall plan x 480mm high
- Planter capacity 150 litres

## Options (ALL MODELS)

- Base moulding in alternative colours
- Timber platform in alternative colour UVP treatment
- Ground fixing plates (pair) for bolting down (generally not required as filled planter typically weighs 200-300kg)

**Planter with horizontal  
half seating platform**

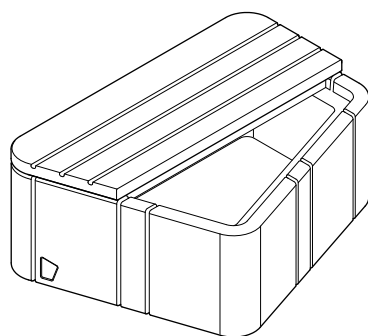
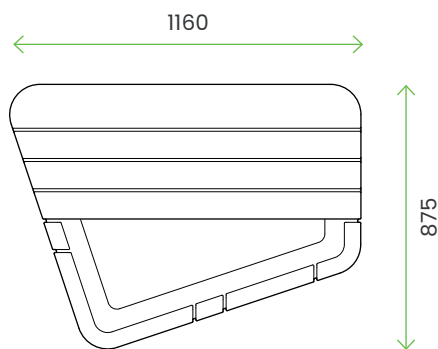

PRODUCT CODE: **UNI RLL**

**Planter with vertical  
half seating platform**

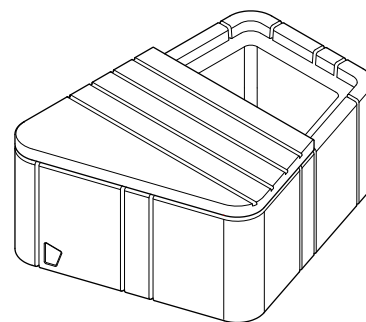
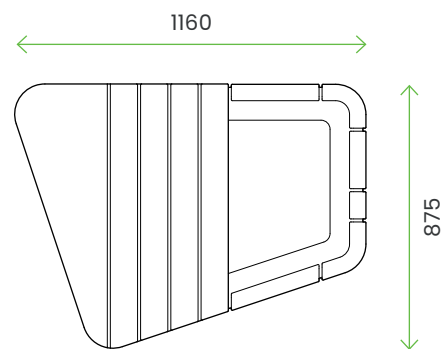

PRODUCT CODE: **UNI RLТ**



# Union planter modules with half seating platform (majority planter)

## General specification

- Low density polyethylene base moulding, mottled dark grey (ref. 9210), with galvanised steel base plate
- Iroko laminated seating platform, smooth planed with UV protective finish
- 1160mm x 875mm overall plan x 480mm high
- Planter capacity 150 litres

## Options (ALL MODELS)

- Base moulding in alternative colours
- Timber platform in alternative colour UVP treatment
- Ground fixing plates (pair) for bolting down (generally not required as filled planter typically weighs 200-300kg)

Planter with horizontal half seating platform

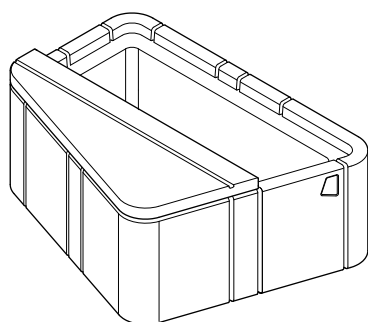
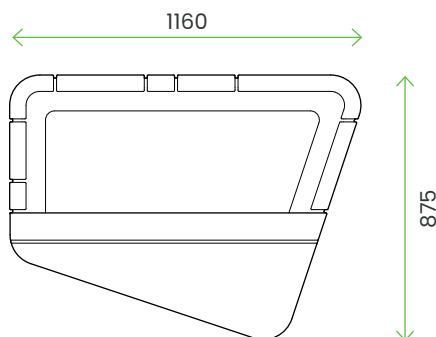

PRODUCT CODE: **UNI SSL**

Planter with vertical half seating platform

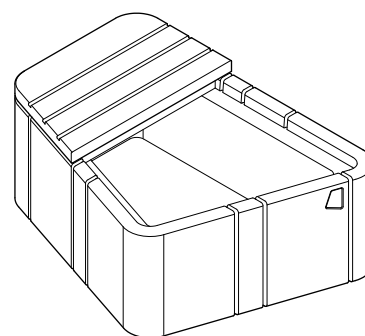
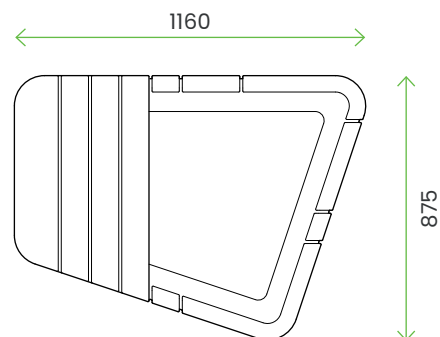

PRODUCT CODE: **UNI SST**

# Union planter modules with half seating platform (majority planter) reverse hand modules

## General specification

- Low density polyethylene base moulding, mottled dark grey (ref. 9210), with galvanised steel base plate, supplied c/w brackets for bolting down
- Iroko laminated seating platform, smooth planed with UV protective finish
- 1160mm x 875mm overall plan x 480mm high
- Planter capacity 150 litres

## Options (ALL MODELS)

- Base moulding in alternative colours
- Timber platform in alternative colour UVP treatment
- Ground fixing plates (pair) for bolting down (generally not required as filled planter typically weighs 200-300kg)

**Planter with horizontal  
half seating platform**

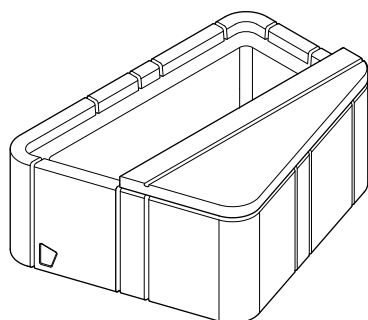
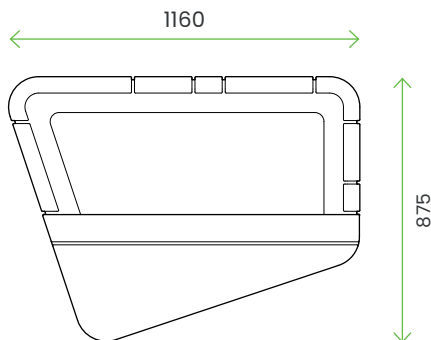

PRODUCT CODE: **UNI RLS**

**Planter with vertical  
half seating platform**

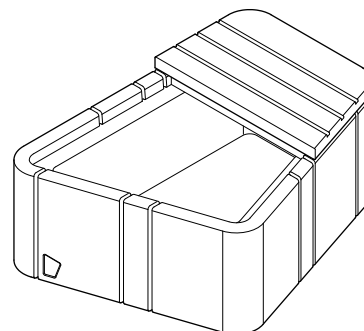
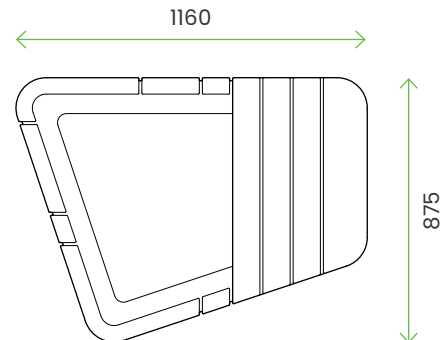

PRODUCT CODE: **UNI RST**

# Uniun all-planter module

## General specification

- Low density polyethylene base moulding, mottled dark grey (ref. 9210), with galvanised steel base plate
- 1160mm x 875mm overall plan x 480mm high
- Planter capacity 150 litres

Planter unit

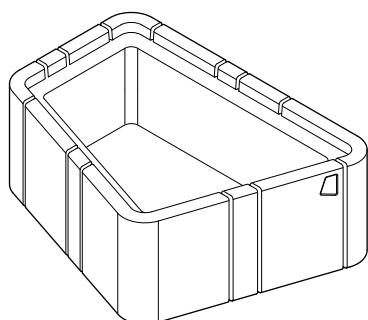
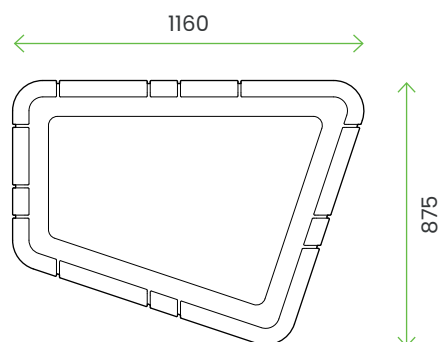

PRODUCT CODE: **UNI SFP**

## Options (ALL MODELS)

- Moulding in alternative colours

Planter unit,  
reverse module

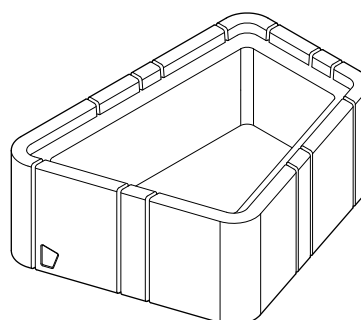
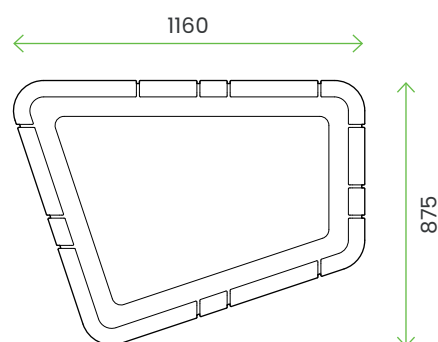

PRODUCT CODE: **UNI RFP**



# Installation.

## Placement and alignment

Grooves on the sides as well as on the top face of the seating platform are designed to help you align the different modules.

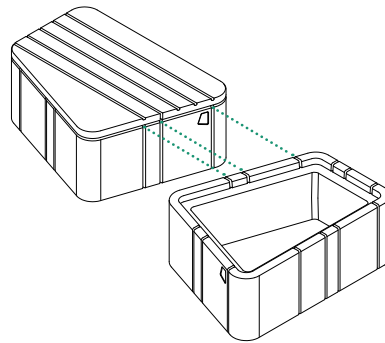

Aligning centre lines of adjacent seating platforms

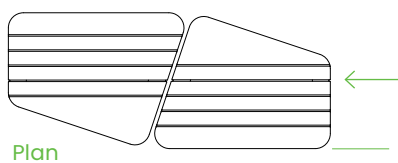

Aligning outside lines of adjacent seating platforms

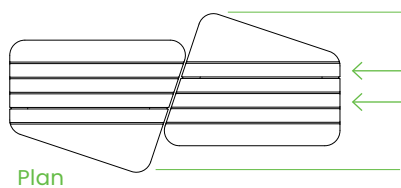

Aligning seating platforms and planters

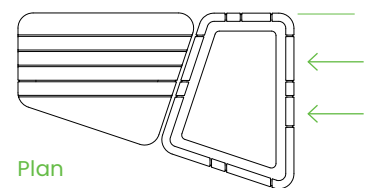

## Levelling and fixing down

- All modules have adjustable feet, allowing for levelling on sloped ground of **up to 50mm** height difference.
- Seating modules are supplied with **2 no. fixing plates** for bolting down.
- A filled planter typically **weighs 200-300kg**, so generally will not require fixing down, though ground fixing plates can be supplied if required.

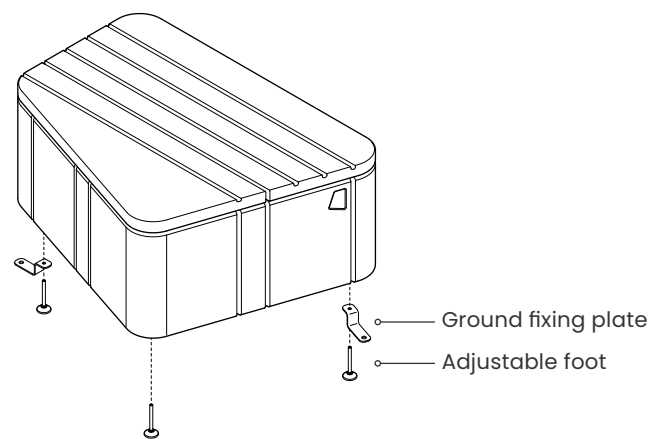

### Section

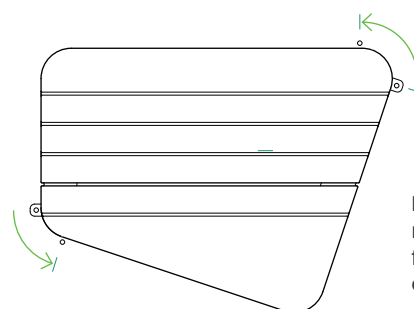
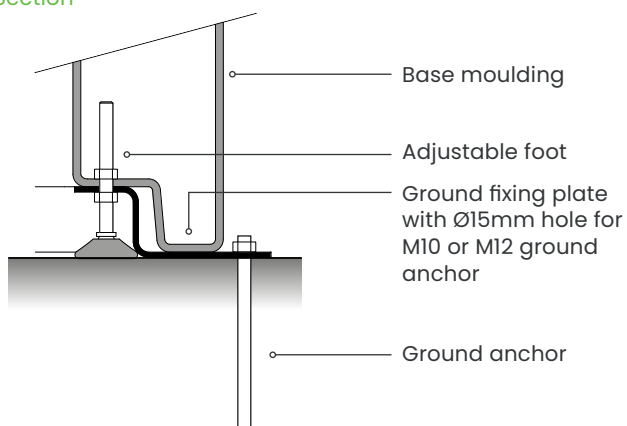

Fixing plates can be rotated so that ground fixings are located in discrete positions

# Case studies.

Some of our recent projects where you can see Union in its full glory

**Client: Ikea**  
Hammersmith, London





# Case studies.



**Uniun**  
**Innova Apartments**  
Croydon, London  
Client: Inspired Homes



# Why Furnitubes.

- **Made in the UK**  
our factory is based in Kent, so expect faster leadtimes and no supply chain delays
- **Easy to maintain + low labour costs**  
we make sure that fixing points are easily accessible so slats and brackets can be changed easily when damaged
- **Modular solutions**  
our ranges are modular and customisable, seating and planters can be easily combined, be creative without blowing the budget
- **Our approach**  
we take a considered approach to design, it's not just about the end product. We take everything in the process into consideration, we are collaborative and we are committed to producing products that improve our environment & keep people safe.



## Our Process.

- **Get in touch** – it's as simple as that, give us a call or drop us an email, we're happy to help whatever the medium!
- **Collaborate** – Depending on your needs, you might not actually need us at this stage, that's the beauty of our modular ranges – they're designed with you in mind, so you can specify with ease. Nevertheless, we are here for you if you do – our design team are always on hand to discuss the nitty gritty of your project.
- **Specification** – This is where our team of experts take the wheel and help you with sketches, CADs and more to help you specify our products as easily as possible.
- **Production + delivery** – all of our products are designed and manufactured in the UK allowing us to give you shorter lead times. With a dedicated project manager keeping you in the loop, you can trust everything is in hand.

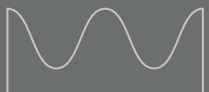
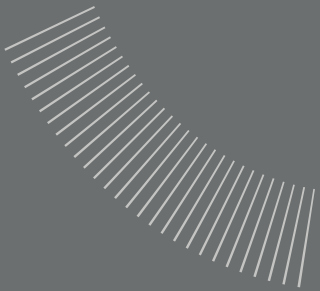
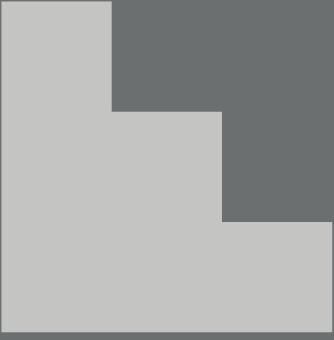



Furnitubes



Furnitubes



Furnitubes International UK

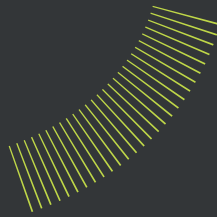

**furnitubes**  
shaping outdoor spaces

T: +44 (0)20 8378 3200  
E: [sales@furnitubes.com](mailto:sales@furnitubes.com)  
[www.furnitubes.com](http://www.furnitubes.com)