

Bollards.

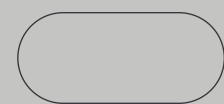

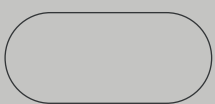

Bollards.

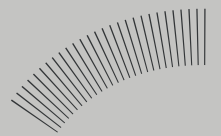
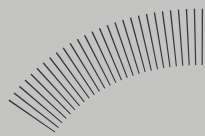
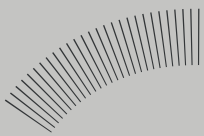
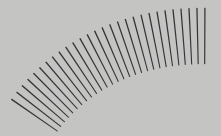
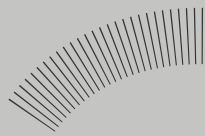
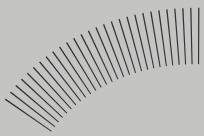
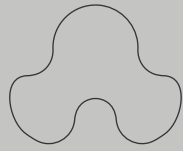
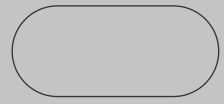
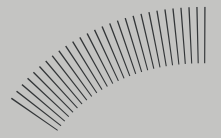
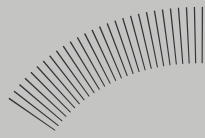
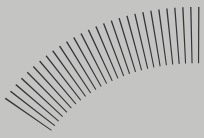
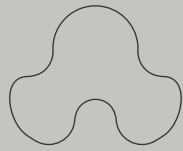
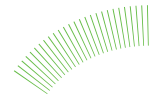

Bollards have been a prominent symbol on our streets for centuries, love them or hate them they serve to protect buildings and pathways and guide pedestrians the right way.

What a load of bollards

Our range come in different shapes, sizes, and materials each having its own aesthetic and function.

Steel and stainless steel posts are most commonly found on pathways and retail developments and cast iron styles are ideal for heritage sites and highways. There are also collapsible / removable bollards that can be folded and stored when not in service, ideal for areas where temporary access is required. Timber bollards naturally weather overtime, making them well suited for countryside environments.

Installing bollards in public spaces are a quick and effective way to enforce unauthorised access to a shops, residential areas or parking spaces. Browse our Bollard range to find the best bollard suited for your scheme. Need help choosing? We offer professional advice to assist your bollard product selection.

Why choose a Furnitubes bollard?

- **You choose** - Various styles and functional options
- **Sustainable** - many of our bollard ranges are made from recyclable materials
- **Easy to maintain** - hardwearing & high-quality products
- **Quick lead times** - on all stock bollards

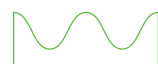

A material for every location.

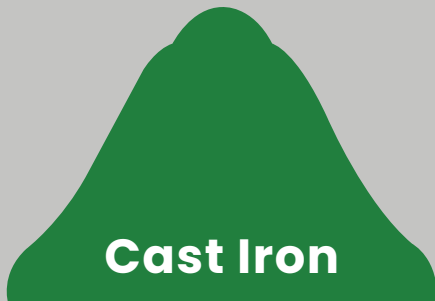

- Supplied in primed finish as standard, for ease of on-site application of top coats
- Removable options; cast in aluminium (excluding Capital)
- Bollards can be painted to a limited selection of **colours**
- Reduce the environmental impact of your scheme, all cast iron bollards are **100% recyclable**



- Our steel bollards are available in a variety of **diameters** and **lengths**
- Grade 304 - suitable for most exterior situations
- Grade 316 - suitable for aggressive environments such as coastal or industrial locations
- Satin polished offered as standard



- Available in Opepe or Oak timber
- Removable options
- Selected ranges are available with grooves or tape
- Our timber bollards are naturally **reusable** and **recyclable**

Cast Iron Bollards.

Timeless & Traditional

Cast iron bollards have been used as boundary markers in our towns and cities for many centuries, and in more recent times as an effective means of segregating pedestrians and vehicles on our increasingly busy streets.

Cast iron bollards are manufactured using traditional founding techniques, giving a distinctive surface finish derived from the sand face of the moulds, and is a process that is particularly suited to creating intricate three dimensional detailing.

CAST IRON BOLLARDS

Cannon



Doric



Bell Bollard 100



Bell Bollard 120

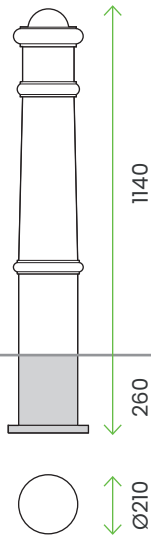

90Kg

Cast aluminium
removable,
lifting weight:
45kg

CAN500

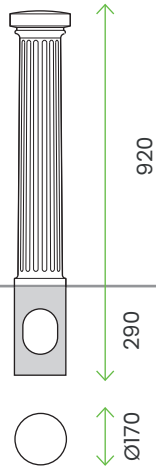

55Kg

Cast aluminium
removable,
lifting weight:
25kg

DOR520

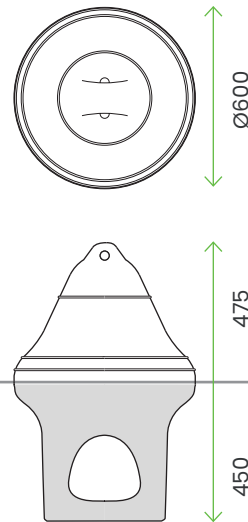

165Kg

Cast iron
traffic bollard

BELL 100

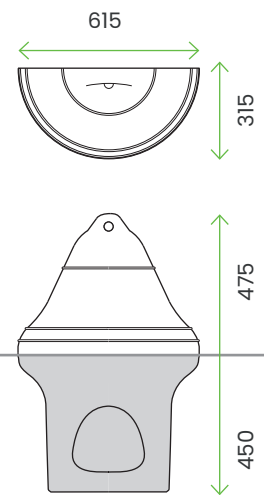

80Kg

Cast iron
traffic bollard

BELL120

Weight

Options

Code

CAST IRON BOLLARDS

Hammersmith



Manchester (Round Base)



City



Capital

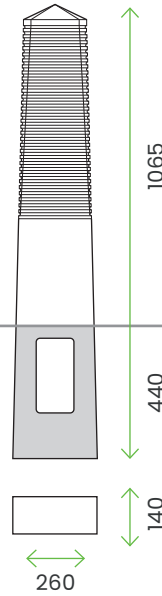
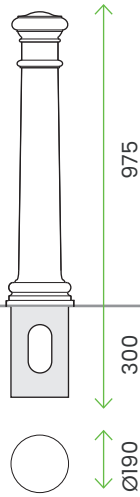
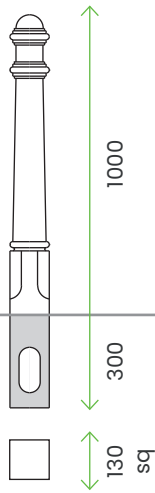

Weight

38Kg

52Kg

100Kg

35Kg

Options

Cast aluminium removable, lifting weight: 20kg

Cast aluminium removable, lifting weight: 25kg

Cast aluminium removable, lifting weight: 30kg

Cast aluminium removable, lifting weight: 16kg

Code

HAM500

MAN536RB

CIT538

CAP100

Extras.

Painting and highlighting

- Paint to a standard RAL colour
- Highlighting to enhance decorative features
- Reflective tape to improve the visibility of a bollard

Removable bollards

For sites where temporary access is required, selected cast iron bollards can be adapted with a choice of 2 socket types, to allow for removal.

- Standard socket
- F1 socket

Installation.

It is important that bollards have a suitable foundation so that they remain firmly in place if they are knocked at any time. Shown below are the minimum recommended requirements for concrete foundation blocks for fixed and removable bollards in typical installations in normal ground conditions.

Particular attention should be paid to the following:

- Set the bollard at the depth / height as shown in the specific bollard illustration
- Ensure concrete penetrates through the below-ground apertures (where applicable) into the internal void of the bollard up to ground level

Fixed bollard

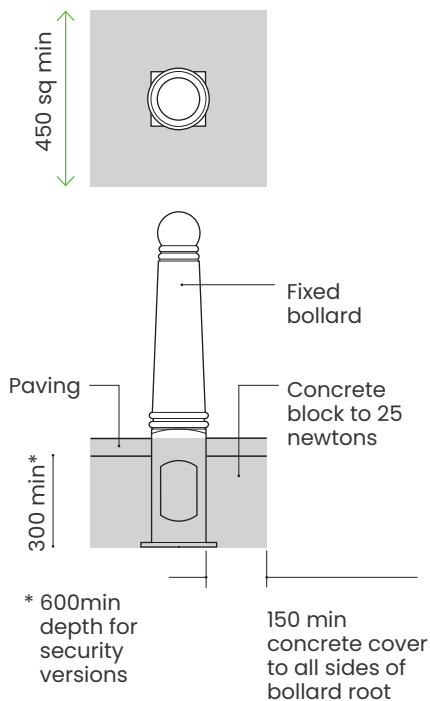

The professional advice of a highway / civil engineer should be sought if there are any queries regarding the ground conditions or doubts over the suitability of the foundation.

Removable bollard: standard socket

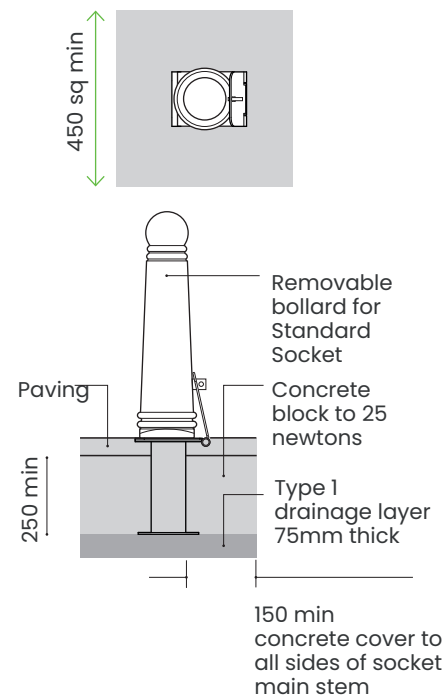

Ensure hinge plate is flush to ground level in closed position

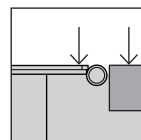

Removable bollard: F1 series socket

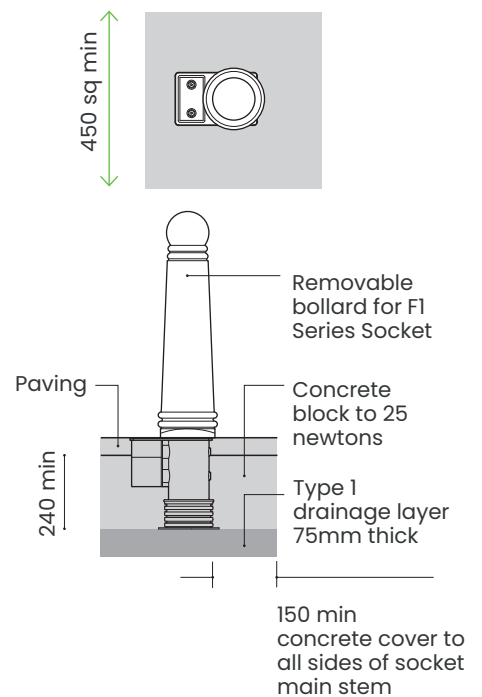

Ensure socket edge is flush to ground level

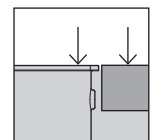

Steel & Stainless Steel Bollards.

Durable, simple yet sleek

Our range of steel and stainless steel bollards is based around standard circular tubular sections, with varying degrees of embellishment – from plain domed versions, to sloped tops.

Steel is not only **super easy to maintain** and **recyclable** it also offers improved tensile strength compared with cast iron.

Steel bollards are light in weight but tough and therefore suited to busy trafficked areas such as; public spaces, car parks and residential areas.

STANDARD ZENITH BOLLARD OPTIONS

Plain



Circular bollard with shallow domed top available in stainless steel, satin finish.

Sloped top



Circular bollard with elliptical top plate sloped at 45 degree angle, available in stainless steel, satin finish.

	Standard Version		Security Version		Standard Version		Security Version	
	A/g	B/g	A/g	B/g	A/g	B/g	A/g	B/g
Ø102mm	900mm	300mm	1000mm	300mm	900mm	300mm	1000mm	300mm
Ø115mm	ZEN701	ZEN701	ZEN801	ZEN701SC	ZEN801	ZEN701SC	ZEN801SC	ZEN701SC
Ø140mm	ZEN703	ZEN703	ZEN803	ZEN703SC	ZEN803	ZEN703SC	ZEN803SC	ZEN703SC
Ø170mm	ZEN704	ZEN704	ZEN804	ZEN704SC	ZEN804	ZEN704SC	ZEN804SC	ZEN704SC

STAINLESS STEEL BOLLARDS

Eltham



Millennium

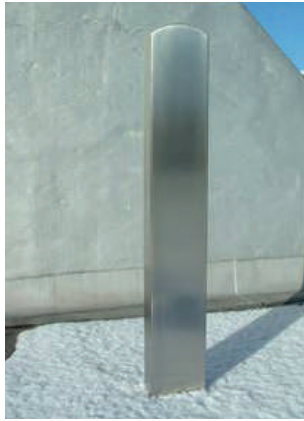

Pinnacle



Transport

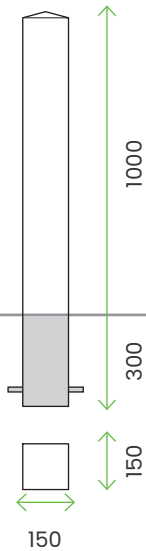

Removable bollard
G316S/S

ELT715S
G304 S/S
satin polished

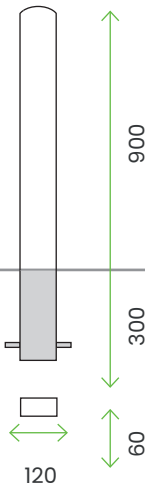

Removable bollard
G316S/S

MIL701BS
G304 S/S
satin polished

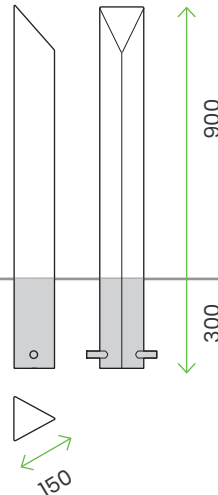

Removable bollard
G316S/S

PIN452S
G304 S/S
satin polished

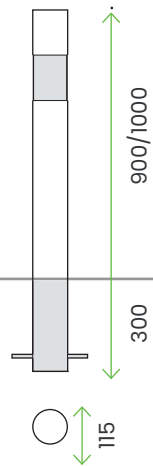

Grade 316 stainless steel, Mild steel galvanised, self-colour or with painted / coated finish, Reflective tape in red, white, yellow, blue, orange and green, Removable bollard

TRL 700
900mm high, S/S
G304, satin polished finish with black reflective tape band

TRL 800
1000mm high, S/S
G304, satin polished finish with black reflective tape band

Options

Code

TELESCOPIC BOLLARDS

Driveway

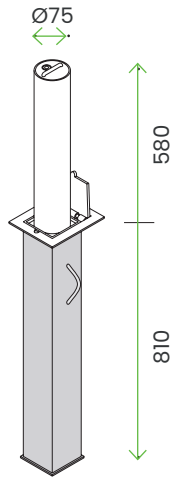

TPR 576

Standard specification, galvanised steel & polyester powder coated finish black or yellow

OPTIONS:
Other BS / RAL colours

LIFTING WEIGHT:
7Kg

Round

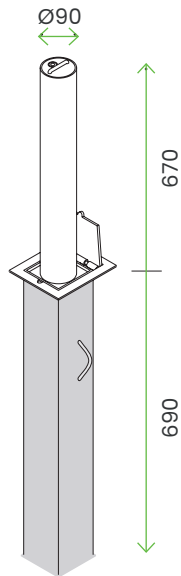

TPR 700

Standard specification, galvanised steel

LIFTING WEIGHT: 12Kg

TPR 800

Anti-ram raid specification, galvanised steel

LIFTING WEIGHT: 14Kg

TPR 390

Anti-ram raid specification, stainless steel in satin finish

LIFTING WEIGHT: 13Kg

Lrg round

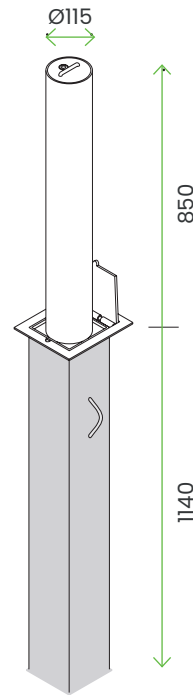

TPR 600

Standard specification, galvanised steel

LIFTING WEIGHT: 17Kg

OPTIONS:
Polyester powder coated

TPR 300

Standard specification, stainless steel in satin finish

LIFTING WEIGHT: 13Kg

Square

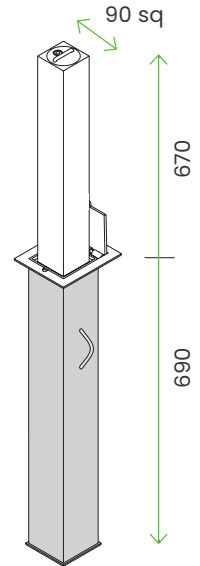

TPR 700

Standard specification, galvanised steel

LIFTING WEIGHT: 13Kg

OPTIONS:
Polyester powder coated

TPR 800

Anti-ram raid specification, galvanised steel

LIFTING WEIGHT: 15Kg

OPTIONS:
Polyester powder coated

Extras.

Reflective Tape

- Reflective tape to improve the visibility of a bollard
- Security version (on selected models)

Materials & Finishes

- Stainless steel – G304 satin polished
- Stainless steel – G316 satin polished

Installation.

It is important that bollards have a suitable foundation so that they remain firmly in place if they are knocked at any time. Shown below are the minimum recommended requirements for concrete foundation blocks for fixed and removable bollards in typical installations in normal ground conditions.

Particular attention should be paid to the following:

- Set the bollard at the depth / height as shown in the specific bollard illustration
- Ensure concrete penetrates through the below-ground apertures (where applicable) into the internal void of the bollard up to ground level

Fixed bollard

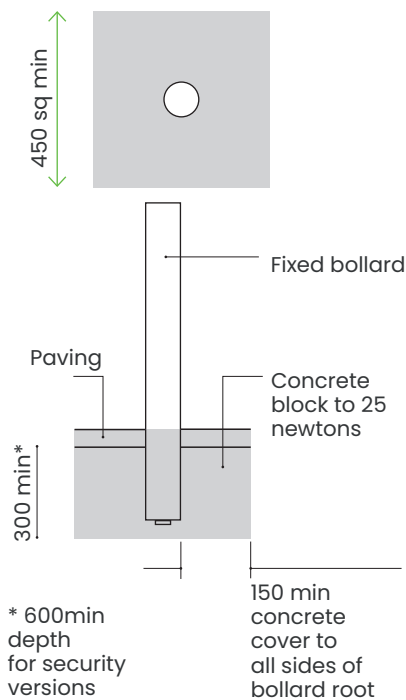

The professional advice of a highway / civil engineer should be sought if there are any queries regarding the ground conditions or doubts over the suitability of the foundation.

Removable bollard: std socket

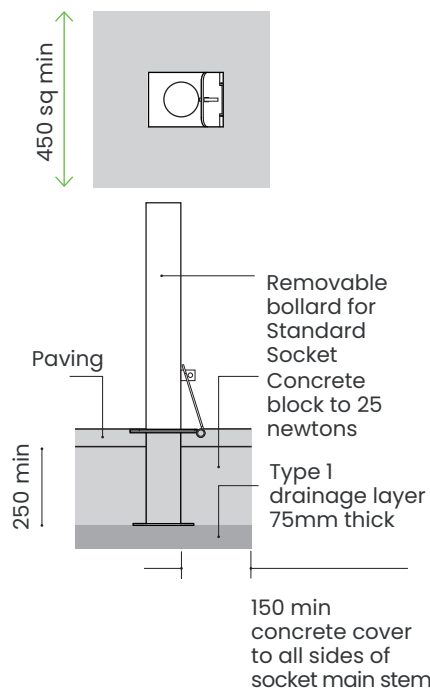

Ensure hinge plate is flush to ground level in closed position

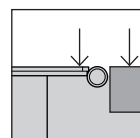

Removable bollard: f1 series socket

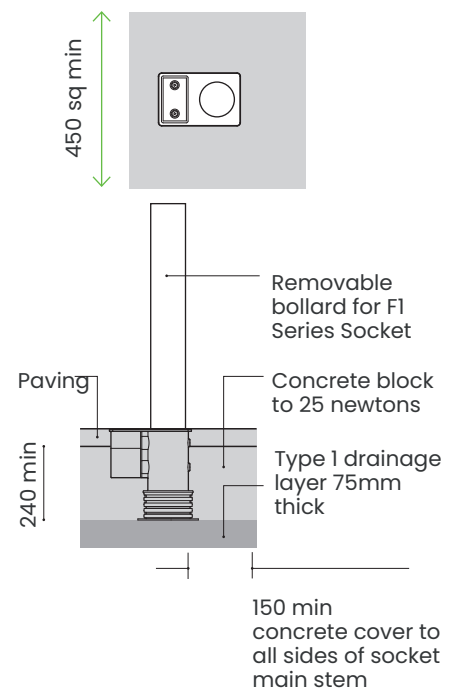

Ensure socket edge is flush to ground level

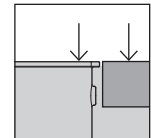

Timber Bollards.

Hard wearing, environmentally friendly

Furnitubes' timber bollards come in three styles - the finely detailed and premium quality **Ashdown** and **Epping** hardwood ranges, and the simple yet effective style of the **Garrick** bollard.

All ranges are offered in several standard sizes and four standard heights above ground between 500mm and 1000mm. We offer machined feature grooves (into which reflective tape can be applied for improved visibility) on all timber bollards.

Ashdown.

Premium circular bollards

Ashdown is a premium range of circular bollards with a high quality machined finish, including a domed top to aid water run-off. The range is particularly suited therefore to urban applications where pedestrians may come into close contact with the bollards, although they are also popular in roadside verge situations.

Opepe - classified as Very Durable hardwood with good fire resistance - is the standard material for the Ashdown range, finished with a coat of woodstain to provide a soft sheen finish and extend the rich colouration as the timber weathers over time.



Ø125-200

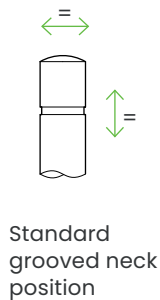
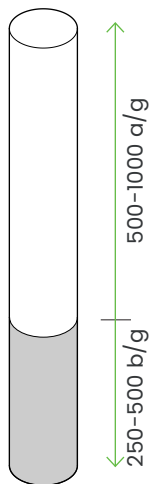

Above Ground

500mm 600mm 800mm 1000mm

Below Ground

250mm 300mm 400mm 500mm

Ø125mm	ARP125750	ARP125900	ARP1251200	ARP1251500
Ø150mm	ARP150750	ARP150900	ARP1501200	ARP1501500
Ø175mm	ARP175750	ARP175900	ARP1751200	ARP1751500
Ø200mm	ARP200750	ARP200900	ARP2001200	ARP2001500

Refer to table for standard section and above / below ground dimension combinations

Standard specification

Opepe hardwood with Sadolin Woodstain finish, colour 'Mais'

Material is subject to availability - alternatives may be offered including Wallebe and Greenheart

Sizes stated are nominal; finished sizes may be reduced due to machining tolerances

Options

- With grooves and optional reflective tape
- Removable bollard with galvanised mild steel or stainless steel socket

Epping.

Premium square bollards

The Epping range are square bollards, with a four-way weathered top and soft chamfered vertical edges, are a popular choice for residential developments in particular.

Manufactured from Opepe hardwood as standard, the bollards offer long term durability and good fire resistance compared with many other timbers. Grooved neck features can be readily machined into the bollards, with the further option of the application of reflective tape to improve their visibility. Other standard options include pre-drilled holes for rails and pre-fitted eyebolts for the chainlink connection.

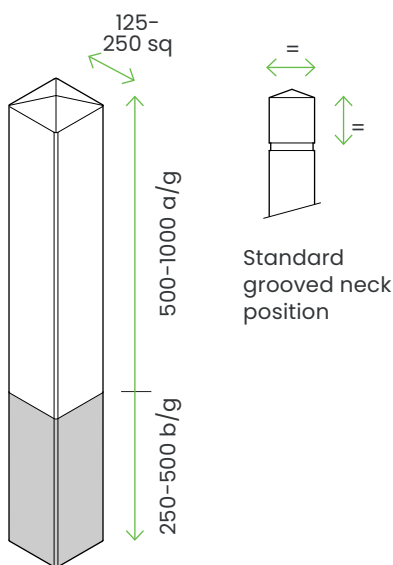

Above Ground

500mm 600mm 800mm 1000mm

Below Ground

250mm 300mm 400mm 500mm

Ø125mm	ESP125750	ESP125900	ESP1251200	ESP125/1500
Ø150mm	ESP150750	ESP150900	ESP1501200	ESP150/1500
Ø175mm	ESP175750	ESP175900	ESP1751200	ESP175/1500
Ø200mm	ESP200750	ESP200900	ESP2001200	ESP200/1500
Ø225mm	ESP225750	ESP225900	ESP2251200	ESP225/1500
Ø250mm	ESP250750	ESP250900	ESP2501200	ESP250/1500

Standard specification

Opepe hardwood with Sadolin Woodstain finish, colour 'Mais'

Material is subject to availability – alternatives may be offered including Wallebe and Greenheart

Sizes stated are nominal; finished sizes may be reduced due to machining tolerances

Options

- With grooves and optional reflective tape
- Removable bollard with galvanised mild steel or stainless steel socket

Refer to table for standard section and above / below ground dimension combinations

Garrick.

Budget-range square bollards

Garrick square bollards are a basic range product in a choice of Green Oak or Pressure Treated Spruce / Whitewood in a planed finish with a four-way weathered top and chamfered edges.

As with all other timber bollards, the Garrick is offered in plain form, with grooves and the option of reflective tape.

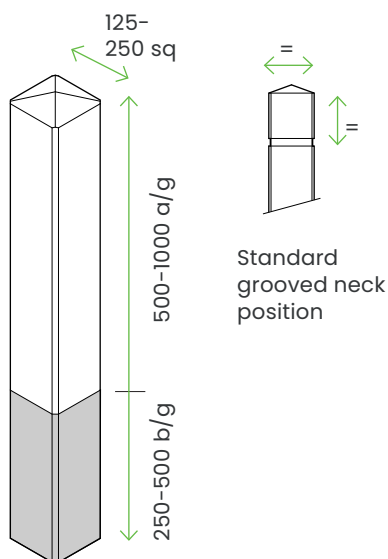

Above Ground

500mm 600mm 800mm 1000mm

Below Ground

250mm 300mm 400mm 500mm

Ø125mm	GAR125750	GAR125900	GAR1251200	GAR1251200
Ø150mm	GAR150750	GAR150900	GAR1501200	GAR1501200
Ø175mm	GAR175750	GAR175900	GAR1751200	GAR1751200
Ø200mm	GAR200750	GAR200900	GAR2001200	GAR2001200
Ø225mm	GAR225750	GAR225900	GAR2251200	GAR2251200
Ø250mm	GAR250750	GAR250900	GAR2501200	GAR2501200

Standard specification

Green Oak or Pressure Treated Spruce / Whitewood (softwood)
 Sizes stated are nominal; finished sizes may be reduced due to machining tolerance

Refer to table for standard section and above / below ground dimension combinations

Options

- With grooves and optional reflective tape

Extras.

Grooves and Tape

- With grooves and optional reflective tape
- Reflective tape to improve the visibility of a bollard

*Please note that the bollard is a loose fit in the socket and is not 100% rigid (but can't be removed if locked) and is not designed for vehicular overrun.

Removable (Ashdown & Epping)

For sites where temporary access is required, selected timber bollards can be adapted to allow for removal.

Comprising a galvanised mild steel or stainless steel socket and a bollard fitted with a locking hasp, suitable for securing with an FB14 padlock (please order separately).

Installation.

It is important that bollards have a suitable foundation so that they remain firmly in place if they are knocked at any time. Shown below are the minimum recommended requirements for concrete foundation block for bollards in a typical installation in normal ground conditions. Particular attention should be paid to setting the bollard at the specified depth below ground / height above ground.

For removable bollard sockets ensure the hinge plate is set flush to ground level in its closed position. The professional advice of a highway / civil engineer should be sought if there are any queries regarding the ground conditions or doubts over the suitability of the foundation.

Fixed bollard

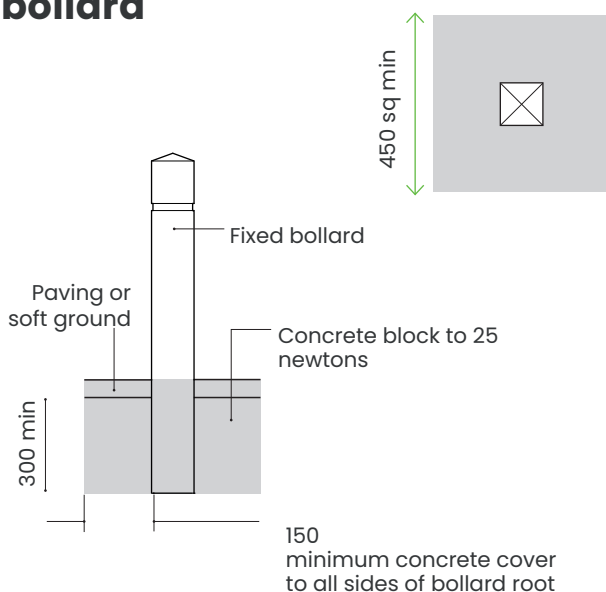

Removable bollard

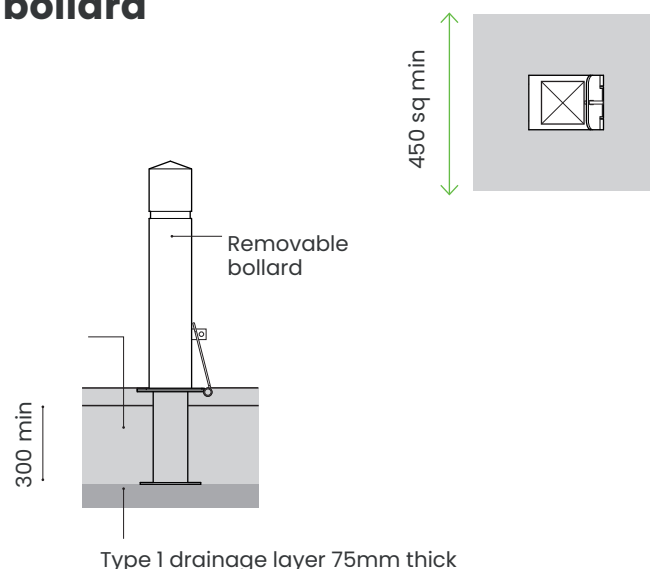

Case studies.

Some of our recent projects where you can see Zenith Bollard in its full glory



Zenith Bollard
Epping Forest
Shopping Park, Essex
Client: McLaughlin
& Harvey

Why Furnitubes.

- **Made in the UK**
our factory is based in Kent, so expect faster leadtimes and no supply chain delays
- **Easy to maintain + low labour costs**
we make sure that fixing points are easily accessible so slats and brackets can be changed easily when damaged
- **Modular solutions**
our ranges are modular and customisable, seating and planters can be easily combined, be creative without blowing the budget
- **Our approach**
we take a considered approach to design, it's not just about the end product. We take everything in the process into consideration, we are collaborative and we are committed to producing products that improve our environment & keep people safe.



Our Process.

- **Get in touch** – it's as simple as that, give us a call or drop us an email, we're happy to help whatever the medium!
- **Collaborate** – Depending on your needs, you might not actually need us at this stage, that's the beauty of our modular ranges – they're designed with you in mind, so you can specify with ease. Nevertheless, we are here for you if you do – our design team are always on hand to discuss the nitty gritty of your project.
- **Specification** – This is where our team of experts take the wheel and help you with sketches, CADs and more to help you specify our products as easily as possible.
- **Production + delivery** – all of our products are designed and manufactured in the UK allowing us to give you shorter lead times. With a dedicated project manager keeping you in the loop, you can trust everything is in hand.

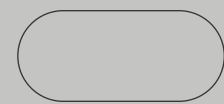
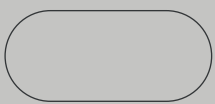
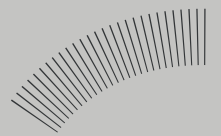
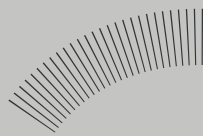
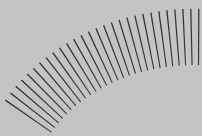
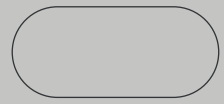
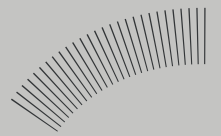
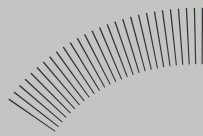
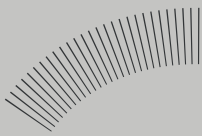
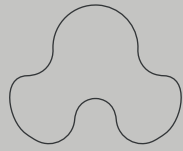
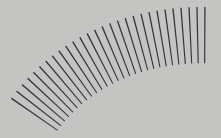
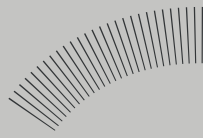
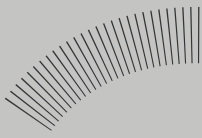



Furnitubes



Furnitubes



Furnitubes International UK

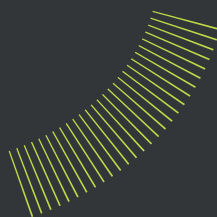

furnitubes
shaping outdoor spaces

T: +44 (0)20 8378 3200
E: sales@furnitubes.com
www.furnitubes.com